

ST100 Instructions

Lift the arm control lever and release the arm and remove it right onto the record, Place the stylus over the selected band on the record. Then move the control lever forwards, allow it to fall freely, it will play when the stylus touches the record. After playing, raise the control lever to lift the stylus from the record and then return the arm to its rest.

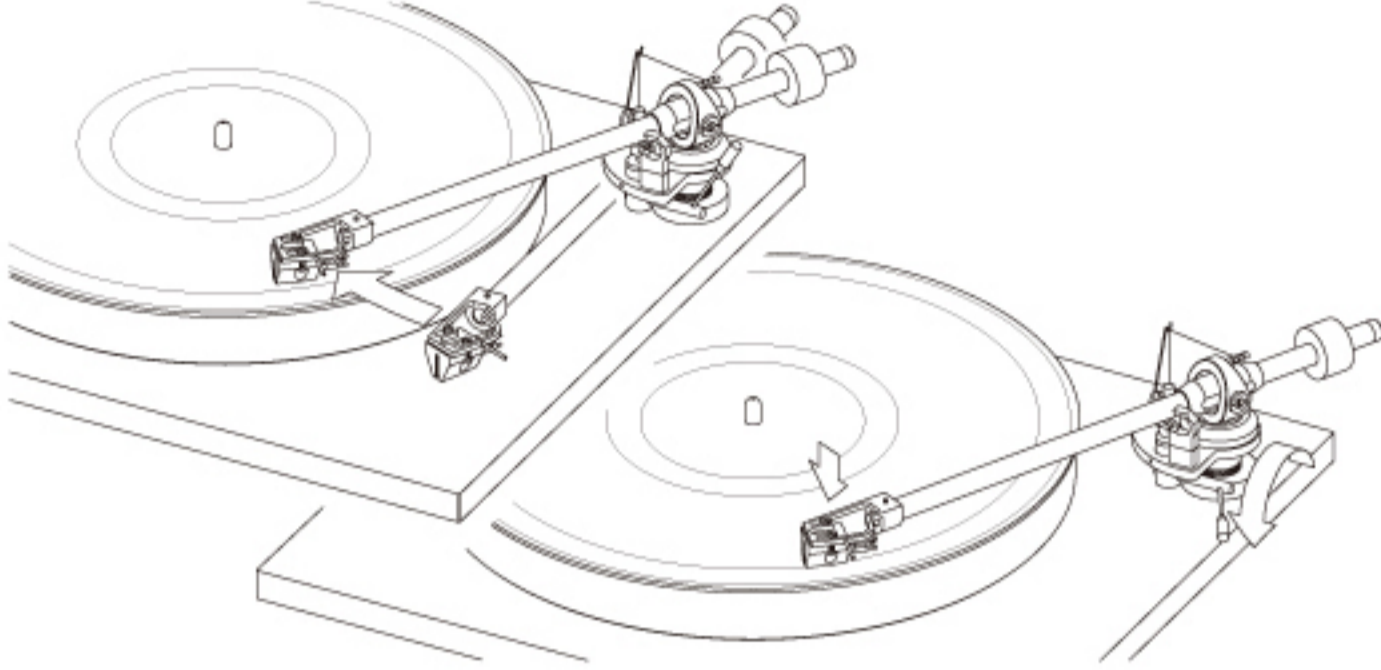

Technical Data	
Model	ST100
Pivot system	Multi-pivot static balance system
Effective length (pivot to stylus)	230 mm (9")
Overhang	16mm
Offset	23.5 degree
Recommend cartridge weight	4-16g
Total weight (without counter weight)	470g
Main counter weight	62g
Incidental counter weight	24g
Anti-skating weight	2g
Arm base and headshell	Stainless steel
Arm tube	Carbon fiber

Note: Don not uninstall the tone-arm, please contact your dealers for further inspection and fixing.



A-ONE & CONSONANCE

www.opera-consonance.com

Email : support@opera-consonance.com



a-one & consonance

ST100

HI-FI TONEARM SERIES

Effective length: 9 "

ST100 Components list

Thanks for you choose A-one & Consonance Hi-Fi Tone-arm Series.
All the parts in the pack are list as followings:

- 1 Tone-arm base and arm(x1)
- 2 Anti-skating weight(x1)
- 3 Counter weight(x1)
- 4 Extra Counter weight(x1)
- 5 Screwdriver for cartridge mounting (x1)
- 6 Cartridge screws and nuts(M2 screws x2,M2 nuts x2)
- 7 Facility meter of stylus press (x1)
- 8 Allen wrenches(M2 x1,M2 x2)
- 9 Manual for installation(x1)

Attention:

Please carefully check that all articles are supplied, mentioned above.

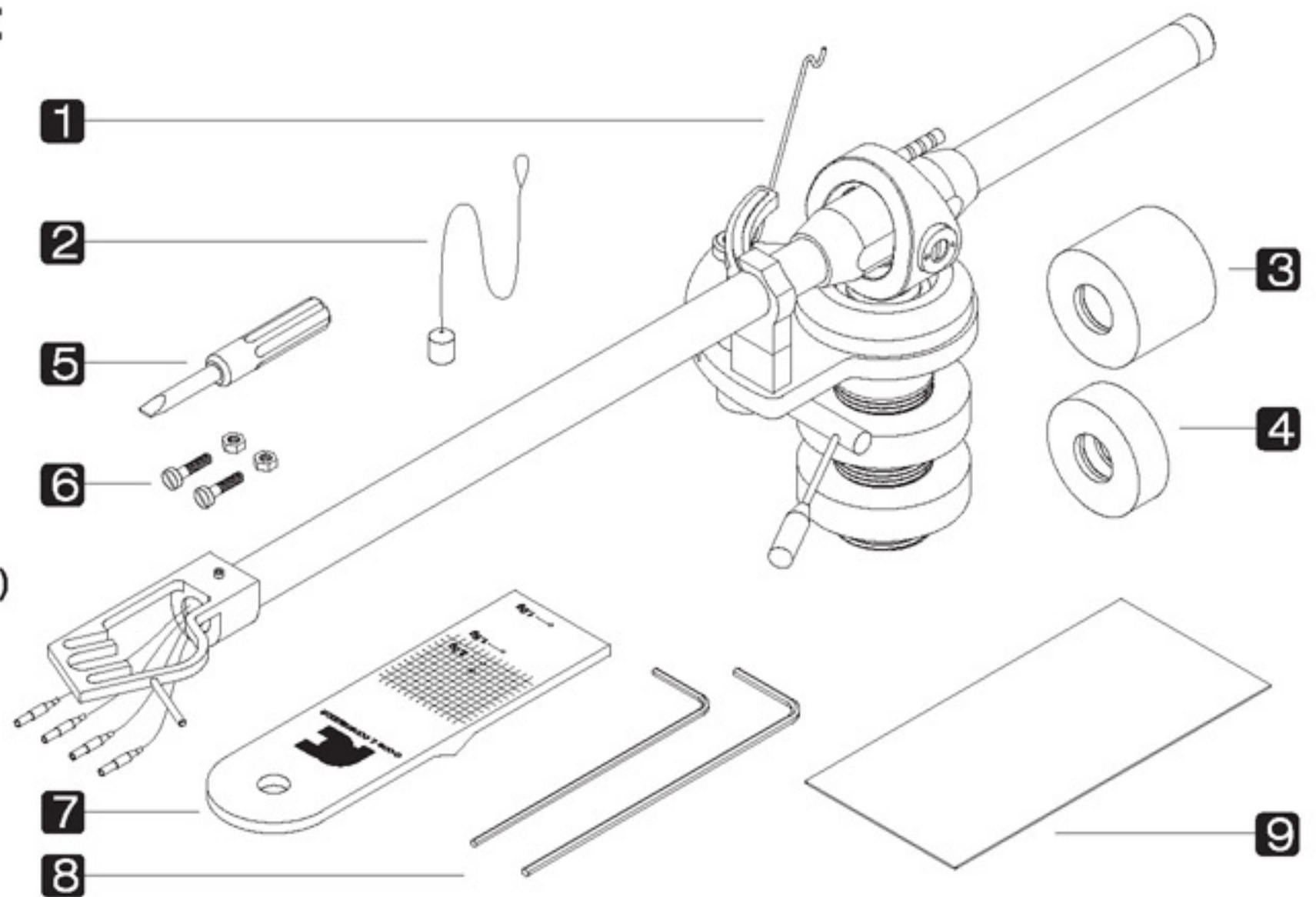

ST100 Installation steps

Before installation please make sure the level distance between the center of mount hole for arm base on the plinth and the platter bearing is 214mm, the diameter of mount hole is 20mm, the thickness of plinth do not over 35mm. Drill each hole completely thru the plinth and make sure they are straight thru. Now you are ready to install the arm. Until the installation finish, please do not remove the tone-arm from the settled shelf for avoiding damaged.

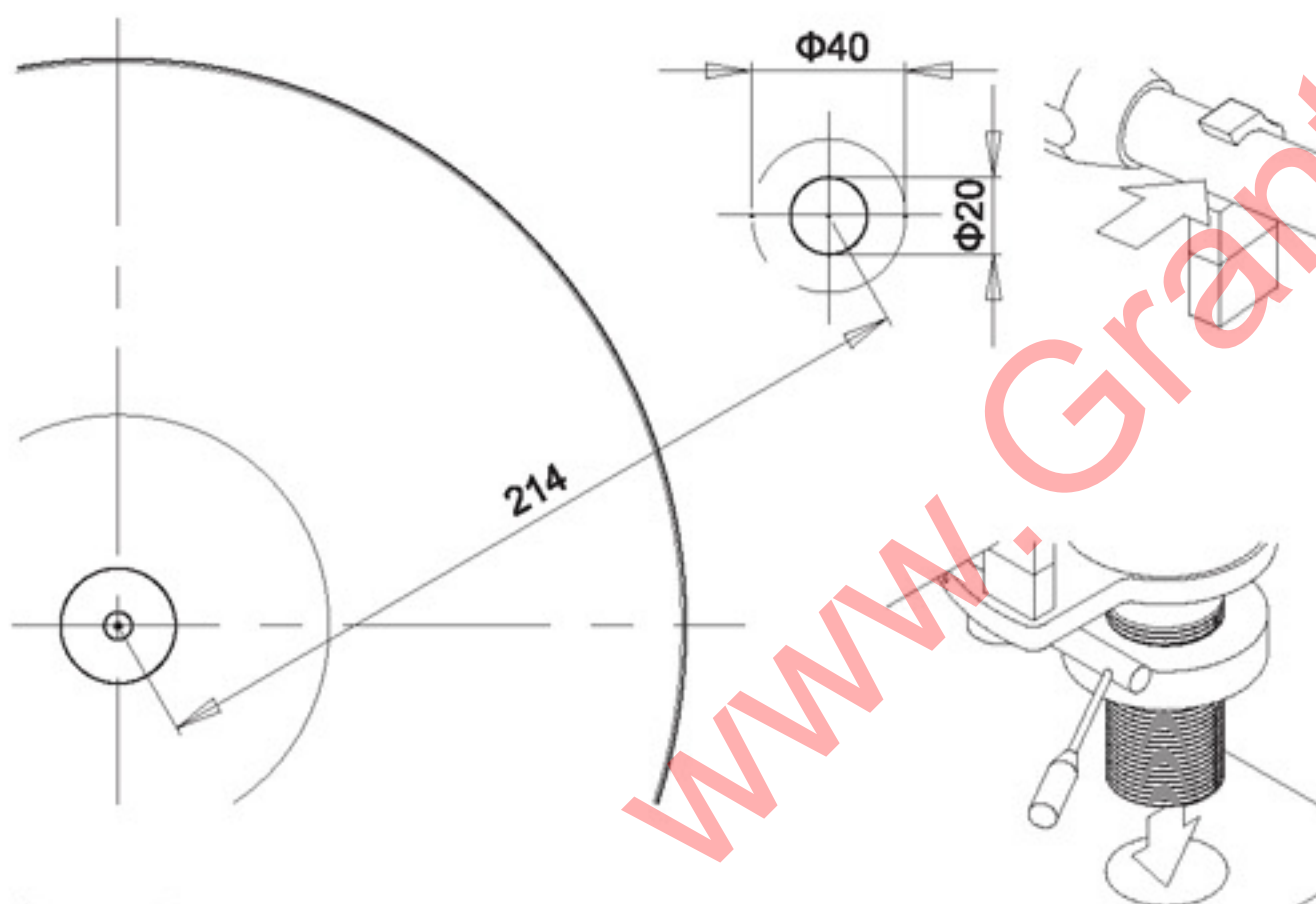

Step 1

There are two nuts on the bottom of arm base, screw off one of them and thru the bottom of arm base across the mount hole. Then screw on the nut under the bedplate for temporary fixing the tone-arm.

Step 2

Take the cartridge mounting screws and nuts (not included) and fix the cartridge to the head shell of tone-arm. Refer to the cartridge manufacturers instructions for proper installation. **Note:** Do not use excessive force on the wires when making the connects or else damage or break could result.

Step 3

Plug the 4 colored terminals (red, green, white, blue) into the back of the cartridge, making sure each color is matched. **Note:** Do not use excessive force on the wires when making the connects or else damage or break could result.

Step 4

Adjustment mechanism nuts until the stylus makes contact with the record. Use the M2 Allen wrench to adjust the head shell so that the cartridge and the record are 90 degree with each other.

Step 5

Take the anti-skating weight with line attached, place the loop over the anti-skating lever. Then hang the line freely over the anti-skating pivot. There are three grooves in the anti-skating lever. The inner groove is calibrated for 1 gram of anti-skating force. The middle groove is 2 grams and the outer groove is 3 grams. Please adjust the anti-skating force appropriately for your cartridge. Place the counter weight on the back of the tone-arm. Adjust the position of the counter weight according to the balance of the tone-arm body and the tracking force of the cartridge.

Step 6

Take the facility meter of stylus pressure, and set on the guide axis. Lift the tone-arm, slightly placed the stylus on the benchmark nearly the guide axis. Look down and the record are 90 degree with each other. Adjust the cartridge, make sure the edge parallels the net meter of the facility meter of stylus pressure.

Step 7

Take down the facility meter of stylus pressure from the guide axis and put on the platter. Install the stylus on the relevant dot of the tracking force. Adjust the position of the tone-arm weight balance carrier, and make sure the facility meter of stylus pressure in a level.

For specific tracking force please refer to the (cartridge) manual !

Step 8

Connect the 5 pin audio cable plug into the 5 pin socket at the back off the ST100, making sure the plug positions are correct.

Note: Don't force the plug excessively or else pin damage will result.

Step 9

Connect the audio cable to your system.

