

ST600 Instructions

Lift the arm control lever and release the arm placing it over the record. Place the stylus over the selected band on the record. Then move the control lever forwards, allowing it to fall freely. When finished, raise the control lever to lift the stylus from the record and then return the arm to its cradle.

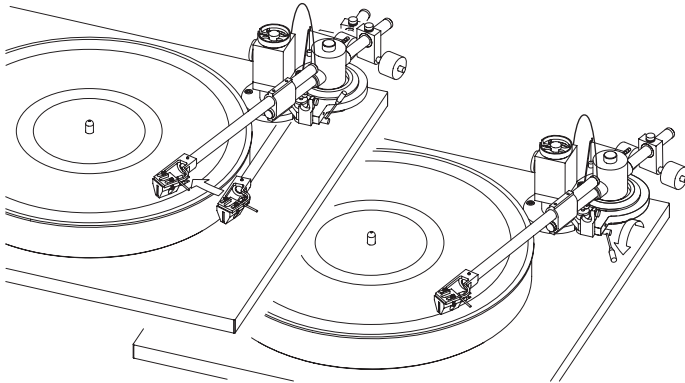

Technical Data	
Model	ST600
Pivot system	Oil damping unipivot dynamic balance system
Effective length (pivot to stylus)	266mm/300 mm (10.5"/12")
Overhang	16mm
Offset	20 degree
Recommend cartridge weight	4-16g
Total weight (without counter weight)	1130g
Main counter weight	50gx2
Incidental counter weight	50g(counter weight balance carrier)
Anti-skating weight	2g
Arm base and headshell	Stainless steel
Arm tube	Carbon fiber

Note: Do not disassemble the tone-arm, please contact your dealer for further inspection and repairs.



A-ONE & CONSONANCE

www.opera-consonance.com
Email: support@opera-consonance.com



a-one & consonance

ST600

HI-FI TONEARM SERIES

Effective length: 10.5 " — 12 "

her side to the end should be the one for the 12 inches positions.

Step 4

Loosen the screw at the side of the height adjustment mechanism and turn the height adjustment gauge on the top until the stylus makes contact with the record. Then retighten the side screw. Using M2 Allen wrench loose the two screws on the top of arm tube connection and adjust the arm tube till azimuth reach 90 degree, retighten the two screws.

Step 5

Take the anti-skating weight with line attached and place the loop over the anti-skating lever. Then hang the line freely over the anti-skating pivot. There are three grooves on the anti-skating lever. The inner groove is calibrated for 1 gram of anti-skating force. The middle groove is 1.5 grams and the outer groove is 2 grams. Please adjust the anti-skating force appropriately for your cartridge.

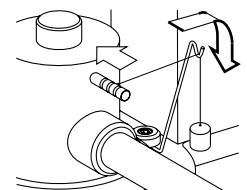

Step 6

Take the tone-arm weight balance carrier and place on the back end of the tone-arm. Then put the two tracking weights on the side rods of the tone-arm weight balance carrier. Adjust the position of the tone-arm weight balance carrier according to the balance of the tone-arm body and the tracking force of the cartridge. For specific tracking force and adjustment methods please refer to the cartridge manual!

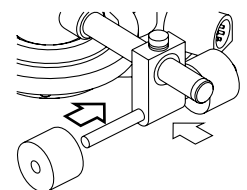

Step 7

Connect the 5 pin audio cable plug into the 5 pin socket at the back of the **ST600**, making sure the plug positions are correct.

Note: Don't force the plug excessively or else pin damage will result.

Step 8

Connect the audio cable to your system.